

# FR-D800(E)

## Quick Start Guide

---



# D800

# Table of Content

---

Table of Content.....	2
1 Overview .....	3
2 Recommended manuals .....	4
3 Product checking.....	5
4 Installation .....	6
4.1 Connection of supply voltage and motor.....	6
5 Operation panel.....	7
5.1 Ethernet model.....	7
5.2 Standard model (serial communication).....	8
6 External control signal connection .....	9
6.1 Analog output AM .....	10
6.2 STO function (Safe Torque off).....	11
7 Parameter settings .....	12
7.1 Advanced magnetic flux vector control.....	13
8 Control using communication .....	14
9 Troubleshooting .....	15
10 Revisions.....	17

# 1 Overview

---

The Quick Start Guide is general for all FR-D800 series inverter.

The FR-D800 is a compact inverter and features a USB-C interface. The Ethernet model offers Ethernet connectivity to be able to control and monitor the inverter via network.

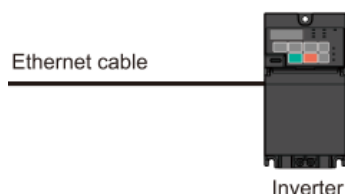

The serial communication model is backward compatible with older models where serial communication was used.



The FR-D800 inverter stands out with its wide range of applications – from horizontal and vertical transport systems to industrial machinery, ventilation, agriculture and the food industry. It supports both induction and permanent magnet (PM) motors, making it suitable for a wide range of equipment.

Using the free FR Configurator 2 software, the inverter can be set up via the USB-C interface without connecting an external supply.

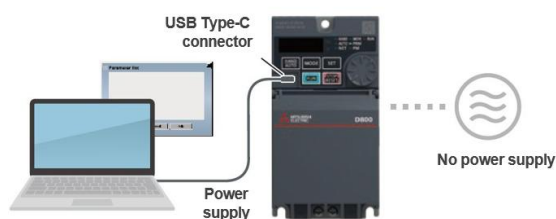

The FR-D800 is available for 1-phase (FR-D820S) or 3-phase (FR-D840) supply. Both variants are available for Ethernet or with serial communication (RS485/RS422). Ethernet models have EPB or EPA in the product code

Example designation FR-D800 Ethernet model: FR-D840-0.4K-012-EPB-60

Example designation FR-D800 Serial communication: FR-D840-0.4K-012-60

There is also the FR-D810W for 1-phase 110 VAC (3-phase 200-240 VAC) but we do not include this model in this document.

## 2 Recommended manuals

Recommendation is to use e-Manual Viewer. E-Manual Viewer contains manuals for all newer products and user selects what to download from server.

Link to e-Manual Viewer 2.04E

[https://www.mitsubishielectric.com/dl/fa/software/update/plc/0000000373/e-manual\\_viewer\\_204e.zip](https://www.mitsubishielectric.com/dl/fa/software/update/plc/0000000373/e-manual_viewer_204e.zip)

Download button for downloading manuals:



In e-Manual Viewer, use search function and select PAGE

Copy links below to search field and press enter to open respective manual.

Example:



FR-D800 manuals:

Name	Link (Page ID)
Instruction manual (Connection)	IB0601031ENG
Instruction manual (Function)	IB0601036ENG
Instruction manual (Communication)	IB0601041ENG
Instruction manual (Maintenance)	IB0601046ENG
Instruction manual (Functional Safety)	BCNA23498003E

Or use tree structure to find manuals.

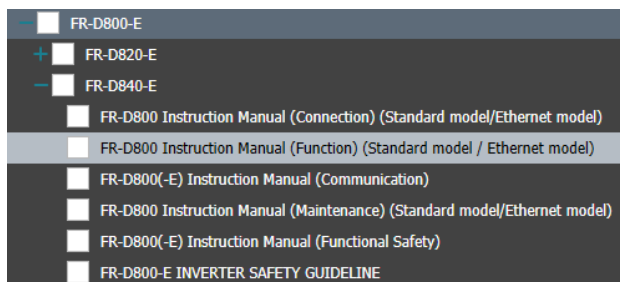

# 3 Product checking

Unpack the product and check the rating plate and the capacity plate of the inverter to ensure that the model agrees with the order and the product is intact.

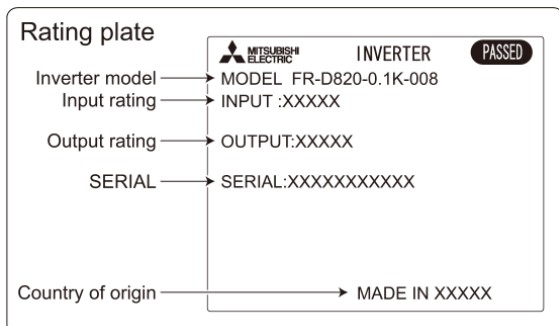

Inverter model code:

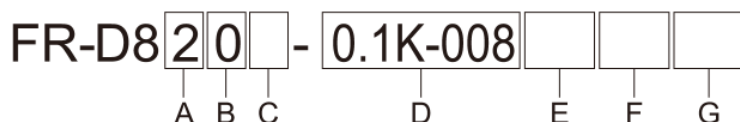

- A: The voltage class is shown.

Symbol	Voltage class
1	100 V class
2	200 V class
4	400 V class

- B: The protective structure is shown.

Symbol	Protective structure
0	Open type (IP20)

- C: The number of phases of the power source is shown.

Symbol	Description
None	Three-phase input
S	Single-phase input
W	Single-phase input (double voltage output)

- D: The applicable motor capacity and the inverter rated current are shown.

Symbol	Description
Example) 200 V class 0.1K-008 to 15K-580	Applicable motor capacity (ND) (kW) - Inverter rated current (ND) (A)

- E: The communication type is shown.

Symbol	Communication
None	RS-485 communication
-E	Ethernet communication

- F: The communication protocol is shown.

Symbol	Protocol specification
None	Mitsubishi inverter protocol, MODBUS RTU
PA <sup>1</sup>	Protocol group A (CC-Link IE TSN, CC-Link IE Field Network Basic, MODBUS/TCP, and EtherNet/IP)
PB <sup>1</sup>	Protocol group B (CC-Link IE TSN, CC-Link IE Field Network Basic, MODBUS/TCP, and PROFINET)

<sup>\*1</sup> To change the protocol group, the firmware of the FR-D800-EPA can be changed from PA to PB, and the firmware of the FR-D800-EPB can be changed from PB to PA. After the firmware change, the protocol group before the change cannot be used. Download the firmware from the Mitsubishi Electric FA Global Website. For details on firmware change, refer to "Firmware update" in the FR Configurator2 Instruction Manual.

<sup>\*2</sup> When changing the firmware from the initial status, be sure not to modify the indication on the rating plate including the inverter model name, such as revising it with a pen and replacing the plate. If the rating plate is modified, the product will not comply with the standards.

- G: Availability of circuit board coating is shown.

Symbol	Circuit board coating <sup>1</sup>
None	Without coating
-60	With coating

## How to read the SERIAL number

### Rating plate example

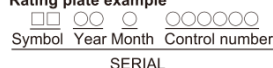

The SERIAL consists of two symbols, three characters indicating the production year and month, and six characters indicating the control number. The last two digits of the production year are indicated as the Year, and the Month is indicated by 1 to 9, X (October), Y (November), or Z (December).

# 4 Installation

Refer to the inverter's instruction manual for sizing fuses and cables and installation instructions.

## 4.1 Connection of supply voltage and motor

L1, L2, L3 and protective earth are connected for 3-phase 400V to our FR-D840 inverters for 3-phase.

**Neutral line (N) must never be connected to a 3-phase model! The terminal block marked N/- is the negative pole of the DC-link.**

L1, N and protective earth are connected to our 1-phase models, see below.

If EMC filters are used, the supply is connected to the EMC filter and then from the EMC filter to the inverter. Normally, the filter is located under the inverter. Ensure that protective earth conductors are connected to earth terminals.

Motor is connected to U, V, W and protective earth. The motor cable must be shielded (braided shield e.g. RKFk, FKKJ-EMC). **Swap two output phases (U, V) if the motor is rotating in the wrong direction.**

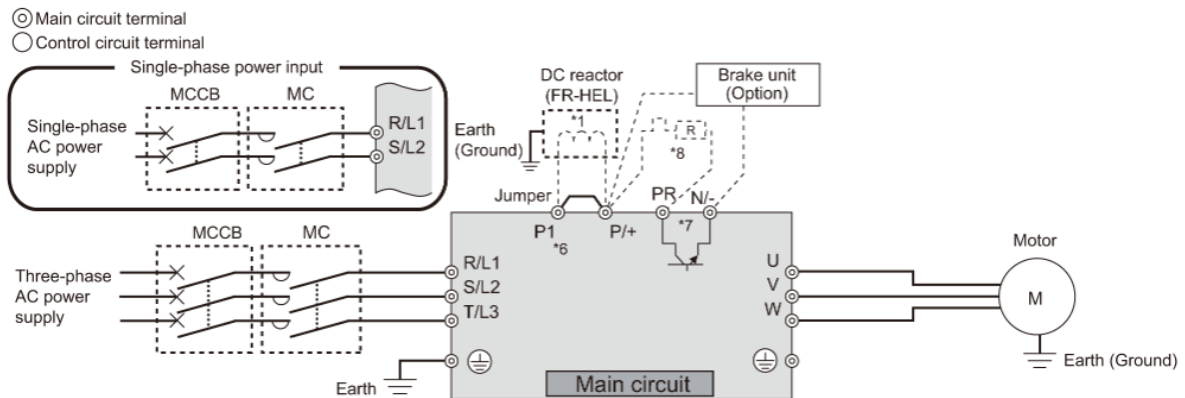

**Brake resistor used to be able to stop quickly or drive regeneratively is connected to P/+ and PR (activate brake chopper with Pr.30=1 and Pr.70, see instruction manual for details).**

**For brake resistor FR-ABR, normal setting for Pr.70 =10%, see manual for details.**

# 5 Operation panel

Note that there are 2 models of operation panel (PU). Operator panel cannot be moved from inverter.

If USB-C cable is connected to PC operation mode PU will be PC (FR Configurator 2, free software used for controlling inverter in PU mode)

## 5.1 Ethernet model

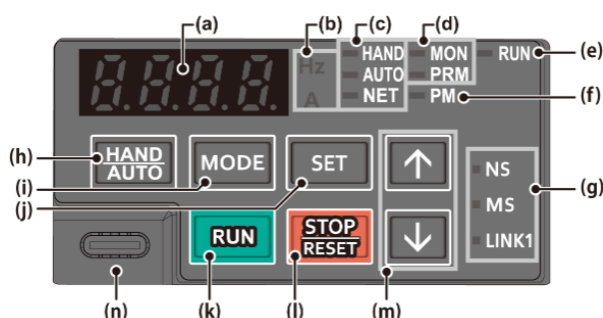

In Hand operation mode the inverter can be started pressing RUN button. Frequency setting value can be adjusted by UP/DOWN key + SET.

If RUN is pressed and no frequency setting value is set the RUN led will flash.

Use MODE to change between Monitor/Parameter Setting/Error History mode.

No.	Appearance	Name	Description	
(a)		Monitor (4-digit LED)	Shows a numeric value (readout) of a monitor item such as the frequency or a parameter number. (The monitor item can be changed according to the settings of Pr.52, Pr.774 to Pr.776.)	
(b)		Unit indication	Hz: ON when the actual frequency is monitored. (Blinks when the set frequency is monitored.) A: ON when the current is monitored. (Both "Hz" and "A" are OFF to indicate a value other than the frequency or the current.)	
(c)		Inverter operation mode LED indicator	HAND: ON when the inverter is in the PU operation mode. AUTO: ON when the inverter is in the External operation mode. NET: ON when the inverter is in the Network operation mode. (ON when the inverter in the initial setting is powered ON.) Both HAND and AUTO are ON when the inverter is in the External/PU combined operation mode 1 or 2.	
(d)		Operation panel mode LED indicator	MON: ON only when the first, second, or third monitor is displayed. PRM: ON when the operation panel is in the parameter setting mode. The indicator blinks when the inverter is in the easy setting mode.	
(e)		Operating status indicator	ON or blinks during inverter running. ON: During forward rotation operation. Blinks slowly (1.4-second cycle): During reverse rotation operation. Blinks quickly (0.2-second cycle): Operation is disabled although the start command is given. <a href="#">1</a>	
(f)		Controlled motor type LED indicator	ON when the PM sensorless vector control is selected. The indicator blinks during test operation. The indicator is OFF when the inverter controls the induction motor.	
(g)		Ethernet communication status	Indicates the Ethernet communication status. For details, refer to the Instruction Manual (Communication).	
(h)		HAND/AUTO key	Switches between the PU operation mode, the PUJOG operation mode, and the Network operation mode. The easy setting of the inverter operation mode is enabled by pressing this key simultaneously with the MODE key. Also cancels the PU stop warning.	
(i)		MODE key	Switches the operation panel to a different mode. The easy setting of the inverter operation mode is enabled by pressing this key simultaneously with the HAND/AUTO key. Every key on the operation panel becomes inoperable by holding this key for two seconds. The key lock function is disabled when Pr.161 = "0 (initial setting)". (Refer to <a href="#">9.7 Automatic frequency setting / key lock operation selection</a> .)	
(j)		SET key	Confirms each selection. When this key is pressed during inverter operation, the monitor item changes. (The monitor item on each screen can be changed according to the settings of Pr.52, Pr.774 to Pr.776.)	<div style="border: 1px solid black; padding: 5px; width: fit-content;"> <p>Initial setting in the monitor mode</p> <pre> graph LR     A[Output frequency] --&gt; B[Output current]     B --&gt; C[Output voltage]     C --&gt; A                     </pre> </div>
(k)		RUN key	Start command The direction of motor rotation depends on the Pr.40 setting. When Pr.40 = "0 (initial value)", the motor starts forward rotation.	
(l)		STOP/RESET key	Stops the operation commands. Used to reset the inverter when the protective function is activated.	
(m)		UP/DOWN key	Used to change the setting of frequency or parameter.	
(n)		USB connector	FR Configurator2 is available by USB connection. (USB Type-C)	

## 5.2 Standard model (serial communication)

Operator panel cannot be moved from inverter.

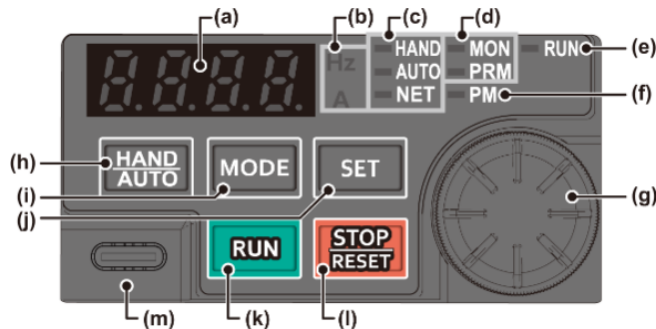

In Hand operation mode the inverter can be started pressing RUN button. Frequency setting value can be adjusted by rotating the setting wheel + SET.

If RUN is pressed and no frequency setting value is set the RUN led will flash.

Use MODE to change between Monitor/Parameter Setting/Error History mode.

No.	Appearance	Name	Description	
(a)		Monitor (4-digit LED)	Shows a numeric value (readout) of a monitor item such as the frequency or a parameter number. (The monitor item can be changed according to the settings of Pr.52, Pr.774 to Pr.776.)	
(b)		Unit indication	Hz: ON when the actual frequency is monitored. (Blinks when the set frequency is monitored.) A: ON when the current is monitored. (Both "Hz" and "A" are OFF to indicate a value other than the frequency or the current.)	
(c)		Inverter operation mode LED indicator	HAND: ON when the inverter is in the PU operation mode. AUTO: ON when the inverter is in the External operation mode. (ON when the inverter in the initial setting is powered ON.) NET: ON when the inverter is in the Network operation mode. Both HAND and AUTO are ON when the inverter is in the External/PU combined operation mode 1 or 2.	
(d)		Operation panel mode LED indicator	MON: ON only when the first, second, or third monitor is displayed. PRM: ON when the operation panel is in the parameter setting mode. The indicator blinks when the inverter is in the easy setting mode.	
(e)		Operating status indicator	ON or blinks during inverter running. ON: During forward rotation operation. Blinks slowly (1.4-second cycle): During reverse rotation operation. Blinks quickly (0.2-second cycle): Operation is disabled although the start command is given. <a href="#">1</a>	
(f)		Controlled motor type LED indicator	ON when the PM sensorless vector control is selected. The indicator blinks during test operation. The indicator is OFF when the inverter controls the induction motor.	
(g)		Setting dial	The setting dial of the Mitsubishi Electric inverters. Turn the setting dial to change the setting of frequency or parameter, etc. Press the setting dial to perform the following operations: · To display a set frequency on the LED display in the monitor mode. (The monitor item shown on the display can be changed by using Pr.992.) · To display the present setting during calibration.	
(h)		HAND/AUTO key	Switches between the PU operation mode, the PUJOG operation mode, and the External operation mode. The easy setting of the inverter operation mode is enabled by pressing this key simultaneously with the MODE key. Also cancels the PU stop warning.	
(i)		MODE key	Switches the operation panel to a different mode. The easy setting of the inverter operation mode is enabled by pressing this key simultaneously with the HAND/AUTO key. Every key on the operation panel becomes inoperable by holding this key for two seconds. The key lock function is disabled when Pr.161 = "0 (initial setting)". (Refer to <a href="#">6.7 Automatic frequency setting / key lock operation selection</a> .)	
(j)		SET key	Confirms each selection. When this key is pressed during inverter operation, the monitor item changes. (The monitor item on each screen can be changed according to the settings of Pr.52, Pr.774 to Pr.776.)	<p>Initial setting in the monitor mode</p> <pre> graph LR     A[Output frequency] --&gt; B[Output current]     B --&gt; C[Output voltage]     C --&gt; A                     </pre>
(k)		RUN key	Start command The direction of motor rotation depends on the Pr.40 setting. When Pr.40 = "0 (initial value)", the motor starts forward rotation.	
(l)		STOP/RESET key	Stops the operation commands. Used to reset the inverter when the protective function is activated.	
(m)		USB connector	FR Configurator2 is available by USB connection. (USB Type-C)	

# 6 External control signal connection

If external 24V is to be used to activate digital inputs, external 0V must be connected to SD. Then the external 24V activates the digital input.

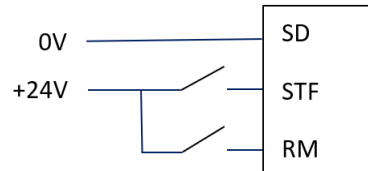

If the inverter's own 24V (PC) is used, connect according to the diagram below. This is the most common method.

To control the motor speed with a 0-10V signal, connect terminal blocks 2(+) and 5(0V)

Pr.73 needs to be changed to 0 for 0-10V (1 = 0-5V).

If the Potentiometer (1kohm 0.5W) is to be used, connect as below. Then Pr.73 should remain on 1. Pr.125 determines frequency reference at 5V/10V signal (default is 50 Hz)

If 4 - 20 mA frequency reference is to be used, this is connected to terminal blocks 4-5. Then digital input must be used to select analogue input 4 instead of analogue input 2. For example, use RL for this and set Pr.180 = 4.

Pr.126 (50 Hz) determines frequency setpoint at 20 mA input signal. Adjust if necessary.

RH, RM, RL selects fixed speeds according to Pr.4, Pr.5, Pr.6. These have priority over Analogue control signals!

Below wiring diagram for model with serial communication (Ethernet model is similar except the FU transistor output, FU is not available on the Ethernet model)

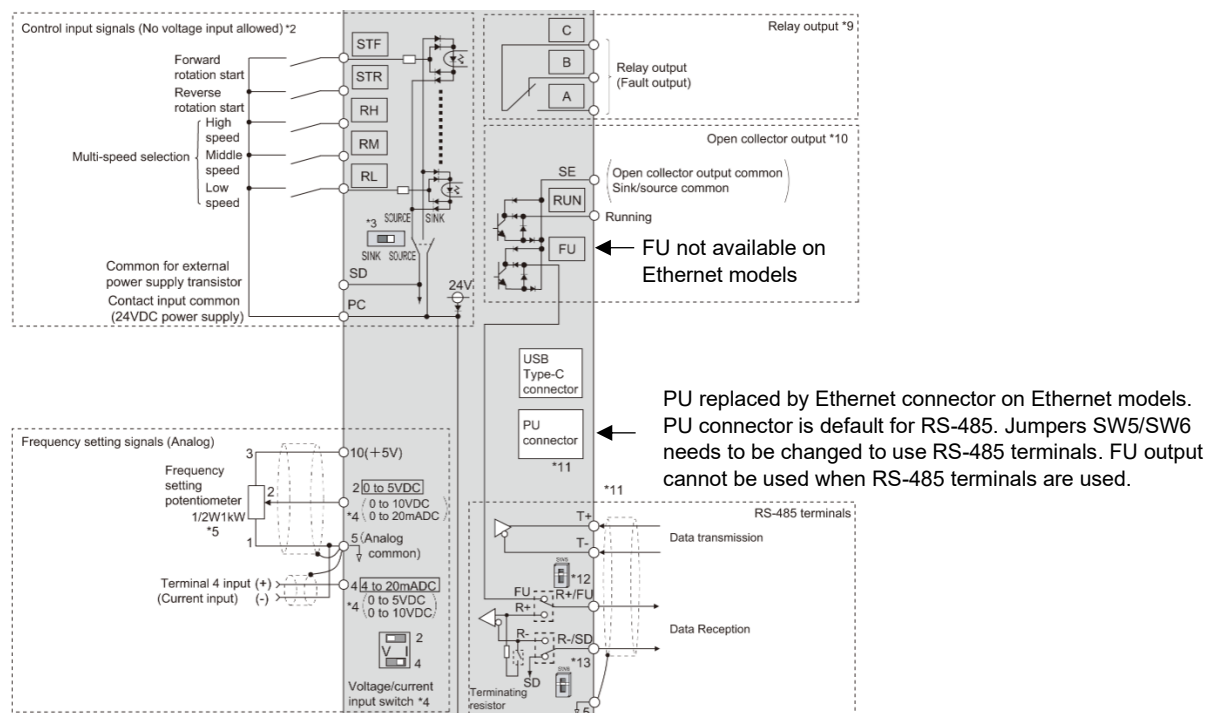

The function of the relay output (A, B, C) can be changed by Pr.192.

The function of the transistor output RUN can be changed by Pr.190. SE terminal block is connected to external 24V or to the inverter's PC if the inverter's internal 24V is to be used (max 0.1 A).

The function of FU (the Ethernet model does not have FU) can be changed by Pr.191.

The default function is output frequency (FU is activated according to Pr.42 setting, default setting is 6 Hz)

See instruction manual for all alternatives for Pr.190 – Pr.192, some examples below. Using settings larger than 100 changes output to negative logic!

Setting		Signal name	Function	Operation	Related parameter	Refer to page
Positive logic	Negative logic					
0	100	RUN	Inverter running	Output during operation when the inverter output frequency reaches Pr.13 Starting frequency or higher.	—	<a href="#">Inverter operation ready (RY) signal and Inverter running (RUN) signal</a>
1	101	SU	Up to frequency	Output when the output frequency reaches the set frequency.	Pr.41	<a href="#">10.7 Output frequency detection</a>
3	103	OL	Overload warning	Output while the stall prevention function works.	Pr.22, Pr.23, Pr.66, Pr.154	<a href="#">9.12 Stall prevention operation</a>
4	104	FU	Output frequency detection	Output when the output frequency reaches the frequency set in Pr.42 (Pr.43 during reverse rotation) or higher.	Pr.42, Pr.43	<a href="#">10.7 Output frequency detection</a>
7	107	RBP	Regenerative brake prealarm	Output when the regenerative brake duty reaches 85% of the setting of Pr.70.	Pr.70	<a href="#">14.8 Regenerative brake selection</a>
8	108	THP	Electronic thermal O/L relay pre-alarm	Output when the cumulative electronic thermal O/L relay value reaches 85% of the trip level. (The electronic thermal O/L relay function (E.THT/E.THM) is activated when the value reaches 100%.)	Pr.9	<a href="#">9.1 Motor overheat protection / electronic thermal O/L relay</a>
11	111	RY	Inverter operation ready	Output when the reset process is completed after powering ON the inverter or when the inverter is ready to start operation with the start signal ON or during operation.	—	<a href="#">Inverter operation ready (RY) signal and Inverter running (RUN) signal</a>

## 6.1 Analog output AM

Default function for AM is output frequency. 10V output at 50 Hz.

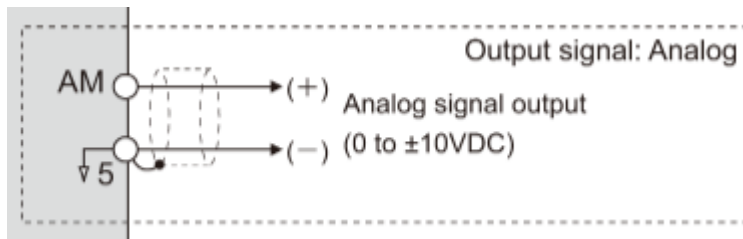

It is possible to change the function of AM using Pr.158. See manual for details.

Monitor item	Increment and unit	Pr.158 (AM) setting	Terminal AM full-scale value
Output frequency	0.01 Hz	1	Pr.55 or the value converted with the Pr.37 or Pr.81 value from Pr.55.
Output current	0.01 A	2	Pr.56
Output voltage	0.1 V	3	100/200 V class: 400 V 400 V class: 800 V
Frequency setting value	0.01 Hz	5	Pr.55 or the value converted with the Pr.37 or Pr.81 value from Pr.55.
Motor speed	1 r/min	6	Pr.55 or the value converted with the Pr.37 or Pr.81 value from Pr.55.
Motor torque	0.1%	7	Pr.866

## 6.2 STO function (Safe Torque off)

The STO function is integrated as standard function in all D800(-E)

The safety stop function of the Mitsubishi Electric FR-D800(-E) inverter can be used to prevent the inverter from supplying rotational energy to motors. Dual input terminals S1 and S2 can be used to cut off the gate-drive power to the IGBT.

This is indicated by **SA** warning code in the inverter's display. S1/S2 should be affected at the same time. If the S1/S2 gets different statuses, there will be a Safety Alarm

**Note that FR starts if the start signal is active when the STO signals are Recovered**

The inverters STO inputs are jumped from the factory. Remove jumpers and connect safety relay if STO is to be used. When External 24V activates the STO, SD must be connected to External 0V.

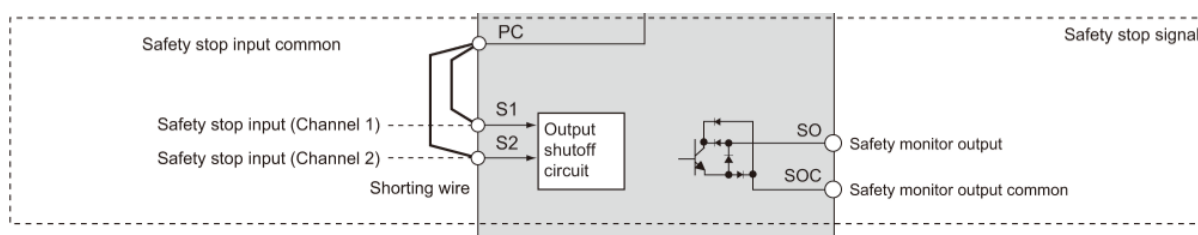

The SO output indicates faults in the safety circuit, e.g. that S1/S2 has different statuses. SO is TRUE in normal state.

Note: Terminal SO cannot be used for safety signals in a safety system. Use terminal SO to output a fault and to prevent restarting of the inverter. Block diagram for STO below.

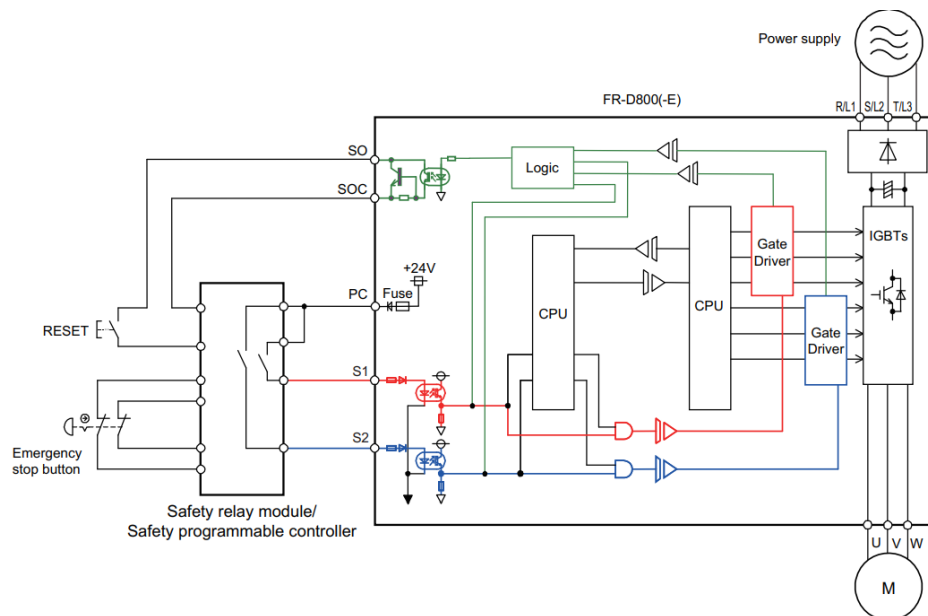

Figure 1 FR-D800(-E) safety stop function diagram

There is a separate manual for the Safety Stop function. There is a more detailed description in the Functional Safety manual for D800(-E).

# 7 Parameter settings

The most typical parameters used in table below. We recommend starting by changing Pr.77 to 2. Then writing is enabled in any operation mode regardless of the operation status.

Operation modes: HAND(PU) = Control with local display, AUTO(EXT) = Control from External terminals, NET = Control using Communication.

Pr	Name	Initial value	Function
1	Maximum Frequency	120 Hz	Upper limit of output frequency
2	Minimum Frequency	0 Hz	Lower limit of output frequency
7	Acceleration time	5/10 s	Acc. time from 0 Hz till 50 Hz (Pr.20)
8	Deceleration time	5/10 s	Dec. time from 50 Hz (Pr.20) to 0 Hz
9	Electronic thermal O/L relay	Inverter rated current	Set motor nominal current in Pr.9. Set 0 to disable when External thermal relay is used.
14	Load pattern selection	0	0 = Linear V/F (constant-torque load) 1 = Square V/F (variable-torque load) 2-3 = Special (see instruction manual)
22	Stall prevention limit	150%	Limitation of motor current. Set in % of the inverter's rated current. PM control, Pr.22 = Torque limit
72	PWM frequency selection	1 kHz	Increase if the switching noise from the motor is disturbing. Keep low. Higher value increases inverter losses.
73	Analog input selection, terminal 2	1 (0-5 V)	<b>0 = 0 - 10 VDC</b> 1 = 0 - 5 VDC
77	Parameter write selection	0	0 = Writing enabled only in stop (PU) 1 = Writing disabled. <b>2 = Parameters can be changed in any operation mode (PU, EXT, NET)</b>
125	Terminal 2 freq. gain	50 Hz	Frequency setpoint at 5/10 V
126	Terminal 4 freq. gain	50 Hz	Frequency setpoint at 20 mA
250	Stop selection	9999	0 = Coast 9999 = ramp stop
340 *1	Communication startup mode selection	0 (10)	0 = Operation mode selected in Pr.79 1 = Start in Network operation mode. 10 = Start in Network operation mode. Possible to change to PU mode.
882	Regeneration avoidance operation selection	0	0 = disabled 1 = The inverter adjusts output frequency regardless of Pr.7/Pr.8 to avoid overvoltage trip (E.OVx)
883	Regeneration avoidance operation level	400 VDC FR-D820(-) 780 VDC FR-D840(-E)	Level at which the inverter starts correcting the output frequency. Lower value reduces the risk of alarms. See instruction manual for details.

\*1 Pr. 340 is set to 10 by default on the Ethernet model (D800-E). Change this to 0 if the inverter is to be controlled (started) using the physical terminals. However, it is possible to use communication for monitoring, e.g. to a GOT panel or Fieldbus.

## 7.1 Advanced magnetic flux vector control

The inverter performs vector calculation and divides its output current into the excitation current and the torque current. In this control mode, the inverter can provide higher torque at low frequencies. Several parameters must then be set and offline autotuning must be done before starting to use this control mode.

The procedure is described below (can alternatively be done using FR Configurator 2).

Start by changing to HAND operation mode by pressing HAND/AUTO.

Pr	Name	Setting	Comment
9	Electronic thermal O/L relay	A	Set the rated motor current
71	Applied motor	3	Standard AC-motor
80	Motor capacity	kW	Set the rated motor power
81	Number of motor poles	Poles	Set according to the motor nameplate. A motor with a rated speed of 1500 rpm at 50 Hz has 4 poles. 3000 rpm = 2 poles.
83	Rated motor voltage	V	Set the rated motor voltage
84	Rated motor frequency	Hz	Set the rated motor frequency
96	Autotuning setting/status	1	<b>Enables auto-tuning in standstill at next start.</b>
800	Control method selection	20	<b>20 = Magnetic flux vector</b> 40 = V/F control

**Any mechanical brake for hanging loads must be interlocked closed for safety reasons!**

To start autotuning, press RUN

Now the display should switch to 2 and the Run indication will appear. The motor does not rotate but in silent environment there is sound from motor.

When autotuning is complete, the display shows 3. Press STOP.

### Tuning status:

Tuning status	Operation panel indication	LCD operation panel (FR-LU08) display
(1) Setting		
(2) During tuning		
(3) Normal completion		

### Possible errors and countermeasures:

Error display	Error cause	Countermeasures
8	Forced end	Set "1" in Pr.96 and retry.
9	Inverter protective function operation	Make the setting again.
91	The current limit (stall prevention) function is activated.	Set the acceleration/deceleration time longer. Set Pr.156 Stall prevention operation selection = "1".
92	The converter output voltage fell to 75% of the rated voltage.	Check for the power supply voltage fluctuation. Check the Pr.83 Rated motor voltage setting.
93	Calculation error. The motor is not connected.	Check the Pr.83 and Pr.84 settings. Check the motor wiring and make the setting again.

## 8 Control using communication

---

Since there are many ways to control FR-D800(-E) using communication the Instruction Manual (Communication) is recommended.

Link to manual using e-Manual Viewer: IB0601041ENG

In general Pr.340 is set to 1 or 10. Then inverter starts in NET operation mode after Reset.

1 = Fixed in NET mode, 10 = NET mode, allows changing to PU using HAND/AUTO button.

### **Ethernet communication is available for Ethernet models FR-D800-EPA, FR-D800-EPB**

Protocols supported by EPA:

- CC-link IEF Basic, CC-link IE TSN
- Modbus TCP
- Ethernet/IP
- SLMP

Protocols supported by EPB:

- CC-link IEF Basic, CC-link IE TSN
- Modbus TCP
- Profinet
- SLMP

### **RS-485 communication is available for the standard model.**

- Use the PU connector or the RS-485 terminals on the inverter as communication interface. When the inverter is connected to a computer, such as a personal computer or one within an FA device, via a communication cable, a user program can run to monitor the inverter operation or read and write parameters.
- Functions such as parameter settings and monitoring are available using the Mitsubishi inverter protocol or MODBUS RTU protocol.
- To make communication between the personal computer and inverter, setting of the communication specifications must be configured in the inverter in advance. Data communication cannot be made if the initial settings are not configured or if there is any setting error.

# 9 Troubleshooting

Refer to instruction manual (Maintenance) for all error codes. Below is a description of typical error codes and warnings.

Error display	Description	Countermeasures
Er2	Parameter writing was attempted during operation	<ul style="list-style-type: none"> <li>• Check that the inverter is stopped.</li> <li>• Change Pr.77 to 2.</li> </ul>
Er4	Parameter writing was attempted when the command source is not at the operation panel (HAND)	Change to HAND operation mode or change Pr.77 to 2.

Warning code	Description	Countermeasures
oLC	The output current of the inverter is higher than setting in Pr.22 current limit	Check the load and Pr.22 setting. Is the motor correctly connected? (Y or Delta) Check that ramp times in Pr.7 and Pr.8 are not too short. Too high value in Pr.0 Torque boost?
PS	PU stop. Stop button pressed in operating mode other than HAND. (AUTO or NET mode)	Remove the start signal and switch to HAND and back to AUTO with the HAND/AUTO button. Alternatively power cycle the inverter.
SA	Appears when safety stop function is activated	Check the status of STO inputs S1, S2

Fault code	Description	Countermeasures
E.OC1	Overcurrent during acceleration Approximately 200% of the inverter's rated current has been exceeded.	Check for output short circuit Check Pr.3 setting (rated frequency) Increase Pr.7 acceleration time Reduce Pr.22 Setting
E.OC2	Overcurrent during constant speed. Approximately 200% of the inverter's rated current has been exceeded.	Check for sudden load change. Check for output short circuit. Reduce the Pr22 setting. Check if the fast-response current limit operation is disabled. See Pr156.
E.OV3	Overvoltage during ramp down or stop. The internal DC voltage has risen too high.	Check Pr.8 Deceleration time. Increase if it is too short. Activate Regen avoidance. See Pr.882. Regen avoidance not recommended for hanging loads! If quick stop ramp is needed, brake resistor (FR-ABR) can be used.
E.THT	Inverter thermal overload. High motor current for a longer time.	Reduce the load. Check Pr.0 Torque boost (decrease) Lower the ambient temperature. Enable Mag. Flux vector. See Chapter 4.1

E.F.H7 E.THM	Motor Thermal Overload	Check Pr.9 setting Check the motor connection. Reduce the load.
E.OLT	Overload. The output frequency has fallen to 1.0 Hz by stall prevention operation and remains for 3 seconds.	Reduce the load. Check Pr.22 Stall prevention limit

Symptom	Description	Countermeasures
Run LED flashes fast (0.2 sec cycle)	Start signal is on but Frequency setpoint is missing. STO activated (SA displayed) MRS activated	Set Pr.2 Minimum Frequency, use Analogue input or activate multi speed input (RL, RM, RH). Send Set Frequency in Network operation mode (NET). Check STO inputs. Check MRS function.
Parameters not stored permanently using FR Configurator 2	Pr.342 = 1, Parameters saved only to RAM while writing parameters via communication	Set Pr.342 = 0 While writing parameter settings via FR Configurator 2 to save permanent in EEPROM. <b>NOTE: If parameters are frequently written via communication Pr.342 must be set to 1 (RAM only) to prevent damaging EEPROM!</b>

# 10 Revisions

---

Date	Document Version	Description	Created by branch	Author
2026-01-07	A	First Edition	MEU-SWE	Johan Blomqvist

---

This manual confers no industrial property rights of any other kind, nor does it confer any patent licenses. Mitsubishi Electric Europe B.V. cannot be held responsible for any problems involving industrial property rights which may occur as a result of using the contents noted in this manual.

---